

Evolved from the rest,
to compete with the best!



FS430

WET BRAKE SYSTEM



ENCLOSED DIFFERENTIAL WET BRAKE SYSTEM



ARTICULATED WHEEL LOADERS

High Power

- Long wheelbase with large breakout force and traction force
- Cummins 6BT5.9-C180 engine with 127kw (180Hp)
- Reinforced drive system
- HungZhou Advanced Transmission

Comfort & Convenience

- Enlarged cabin space
- Low noise, shock-absorbed and dust-proof cab
- Rear opening engine hood, for easy maintenance
- Pilot control Joystick
- High volume air conditioned pressurised cabin
- Automatic bucket levelling

Reliability & Durability

- Upgraded hydraulic system
- New design electrical system
- Optimal designed structural components

Safety

- ROPS cab
- Internal Wet Brake System
- Luxurious operating environment

Energy Saving & Green Initiative

- Low fuel and energy consumption
- Low noise



PH: 1800 566 080

WWW.OLYMPUSLOADERS.COM.AU



FS430

ARTICULATED WHEEL LOADERS

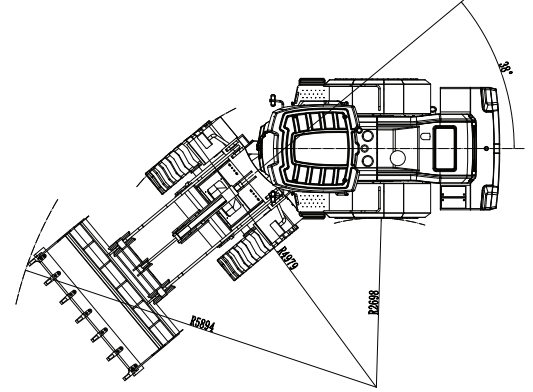
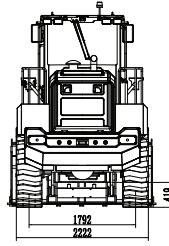
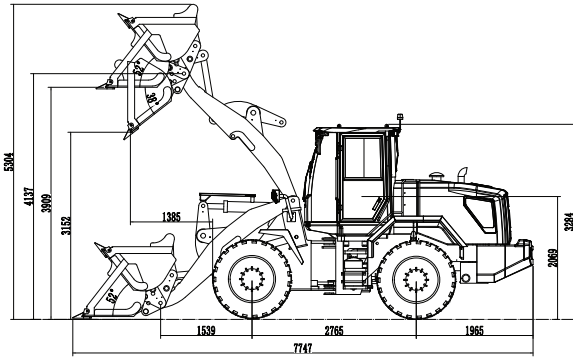

SPECIFICATIONS

Overall Weight	13,000kg
LxWxH (mm)	7050 x 2430 x 3200
Rated Bucket capacity (m3)	2.4m ³
Lift Capacity (kg)	4200
Max. Dump Height (mm)	3800
Bucket Indicator	Auto Bucket Leveling

ENGINE

Model	Cummins 6BT5.9-C180
Type	Vertical Inline, Water Cooling Four Stroke Turbo Diesel
Rated Power (kw)	127kw (180HP)
Rated Speed (r/min)	2400

TRANSMISSION SYSTEM

Model	HungZhou Advanced
Gearbox Type	Electronic Powershift
Gear Shift	4 Forward, 4 Reverse

MAIN HYDRAULIC SYSTEM

Working Pressure	18mpa
Boom Lifting Time	4.8sec
Fuel Tank Capacity	200Lt

STEERING SYSTEM

Type	Load Sensing Hydraulic Steering
Min Turn Radius (mm)	6000

TYRES

Standard Tyres	20.5-25
----------------	---------

STANDARD

Width (mm)	2480
------------	------

ROPS CERTIFIED CABIN

With its high volume Air Conditioner upgrade we have created a much better cooling system for Australia, combined with a sealed cabin it eliminates noise and dust from its working conditions. The sealed cabin has a AM/FM stereo, reversing camera, external fan, suspension seat and tilting steering wheel with warning lights for engine and transmission management.

MODERN CONTROLS

On the dash there is bucket float control activation and all the switches for lights, windscreen washer and accessories, etc. The pilot control joy stick is smooth and light to operate giving sensitive feeling to the operation of the loader's bucket. Auto bucket to dig leveling is also standard. A large rear vision camera is fitted inside the cab for safe, easy reversing.

BRAKING SYSTEM

Olympus FS430 Models run a newly designed Wet Brake System, using internal oil wet disc brakes. The braking system is enclosed within the differentials in an oil soak bath for longevity and protection of the braking system, ideal for wet dam cleaning and stick raking.

MULTI PURPOSE TOOL HANDLING

Hydraulic hitches are able to quickly change attachments; from bucket to hayspears to pallet forks within a few seconds. This is achieved from an auxiliary hydraulic function also able to run hydraulic attachments i.e., augers, 4in1 buckets, hydraulic forks etc.



Olympus Equipment Sales
E: sales@olympusloaders.com.au
P: Simon - 0427 744 049
2/25-29 Riverland Drive
Loganholme Q. 4129

PH: 1800 566 080

WWW.OLYMPUSLOADERS.COM.AU